



EVO2000 M-Series

Single Module
200W~320W
Up to 170 lm/w
Marine Grade

Smart control available

Specification

Model	EVO2320MLX	EVO2280MLX	EVO2250MLX	EVO2220MLX	EVO2200MLX
Rated Watts	320W	280W	250W	220W	200W
Range	300W~320W	270W~290W	240W~260W	200W~230W	200W
LED Chips					
CRI	≥70 (Cool White), ≥80 (Natural & Warm White), ≥90 (optional)				
LED nos.	320pcs				
Total Luminous flux (Cool white)	≥49,600 lm ≥ 155 lm/w	≥44,800 lm ≥ 160 lm/w	≥40,500 lm ≥ 162 lm/w	≥36,300 lm ≥ 165 lm/w	≥34,000 lm ≥ 170 lm/w
Driver	MeanWell XLG-320		MeanWell XLG-240		MeanWell XLG-200
AC Input	AC 100~277V				
Dimming	0-10V				
Operation Temp.	-40°C~55°C, indoors and outdoors				
IP rating	IP66				
Beam Angle	15°/30°/45°/60°/90°, PC AIO Lens Tear-Drop Technology				
Color Temp.	5000K~5700K(CW)/4000K(NW)/ 2700K~3000K(WW)				
Dimensions	403x250x205mm (include bracket)				
Weight	6.4 Kg	6.5 Kg		6.6 Kg	
Material	Die-cast Aluminum Heat-Sink, Grey painting AIO PC Lens Cover/ UV Cut Stainless 304 Bracket Straight and 30° Tilt bracket (Optional)				
Industrial Certificate	1000+hrs Salty-Spray (ASTM B117) testing passed > =62m/sec wind pressure testing passed 3G Vibration /IEC 62471 Photo-biological Safety passed				
Smart Controlling	Neotroni ECO-Link: Zigbee/DALI Neotroni PowerLink: LoRa/NBIOT/LTE/PLC (Power Line Communication)				
Warranty	5 Years, Life Span > =50,000 hrs				
COO	Made in Taiwan				
Certification	CE/CNS/ROHS				

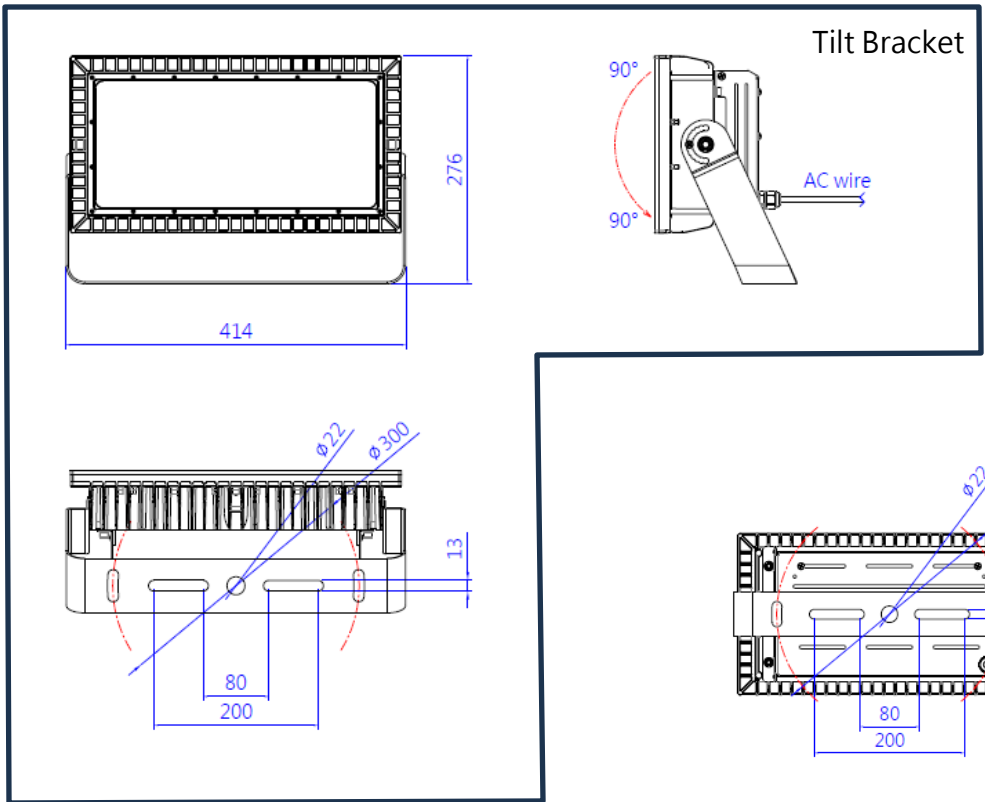

Tilt Bracket

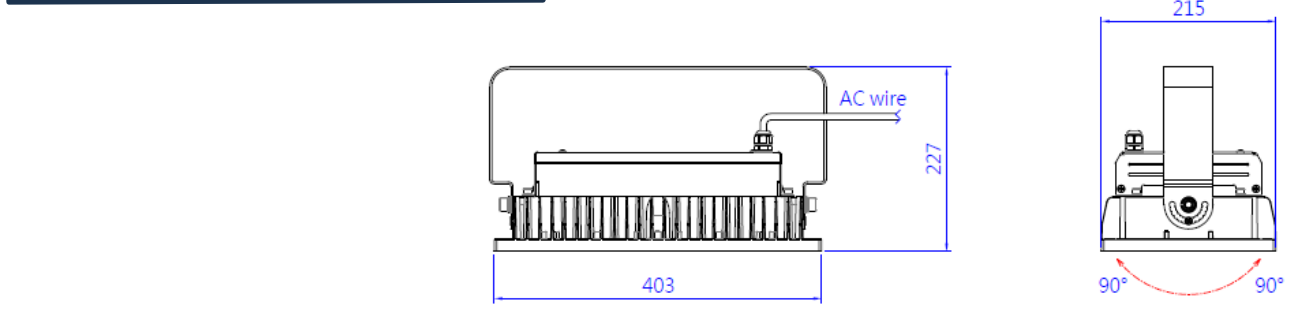

Straight Bracket

